

Captive Screw Type 2 10-32 Thread

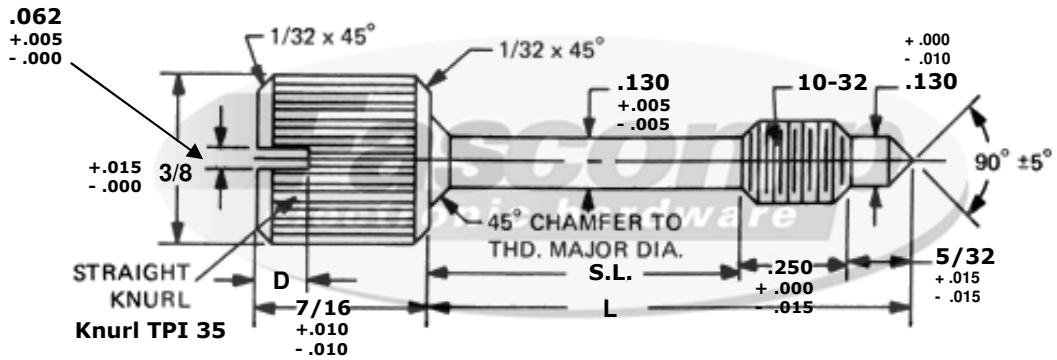

Create a part number:

Length	Material	Finish
FCXXXX	XX	XX

Captive Screws - 10-32 Thread				
FCXXXX	Length (L)	S.L. +.010 -.010	D. +.010 -.000	
FC0442	1/2	3/32	.093	
FC0443	9/16	5/32	.093	
FC0444	5/8	7/32	.093	
FC0445	11/16	9/32	.093	
FC0446	3/4	11/32	.093	
FC0447	13/16	13/32	.093	
FC0448	7/8	15/32	.093	
FC0449	15/16	17/32	.093	
FC0450	1	19/32	.093	
FC0451	1-1/16	21/32	.093	
FC0452	1-1/8	23/32	.093	
FC0453	1-3/16	25/32	.093	
FC0454	1-1/4	27/32	.093	
FC0455	1-5/16	29/32	.093	
FC0456	1-3/8	31/32	.093	
FC0457	1-7/16	1-1/32	.093	
FC0458	1-1/2	1-3/32	.093	
FC0459	1-9/16	1-5/32	.093	
FC0460	1-5/8	1-7/32	.093	
FC0461	1-11/16	1-9/32	.093	
FC0462	1-3/4	1-11/32	.093	
FC0463	1-13/16	1-13/32	.093	
FC0464	1-7/8	1-15/32	.093	
FC0465	1-15/16	1-17/32	.093	
FC0466	2	1-19/32	.093	

Material	
Material Code (XX)	
B	Brass
S	Steel
SS	Stainless Steel

Compatible Finish (XX)	
B, S, SS	0 - Plain
B, S	5 - Nickel Plate (QQ-N-290)
B, S	12 - Zinc Clear (ASTM-B-633)
B, S	16 - Electro Tin (MIL-T-10727 TYPE 1)
SS	20 - Passivation (MIL-F-14072D)
B, S, SS	26 - Black Oxide
B, S	28 - Zinc Yellow (ASTM-B-633)

Source Control Drawing:
To be produced by
Fascomp Electronic Hardware

Tolerances Unless otherwise Specified
 .xxx +/- .005
 .xx +/- .010
 Angular +/- 1 Degree
 Linear +/- .005
Break all sharp edges



This document is the property of Fascomp Inc. and shall not be reproduced, distributed, or used as a basis for manufacturing without written permission from Fascomp Inc.